

Sparrow

By Perry Bailey Copyright 2000

Use Mono colored paper
or the head will be a different
color than the body.

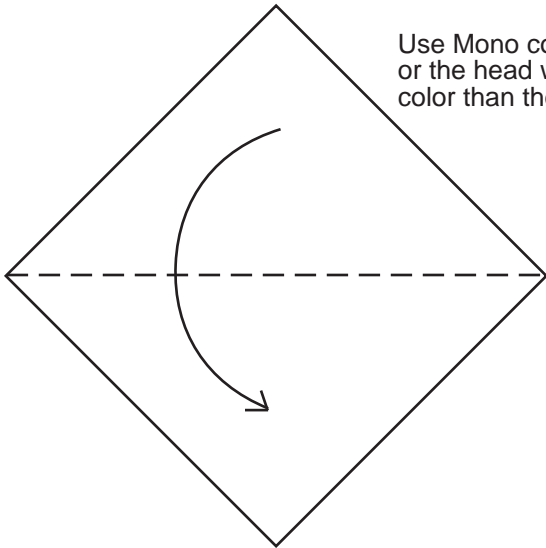

1. Fold in half on the diagonal.

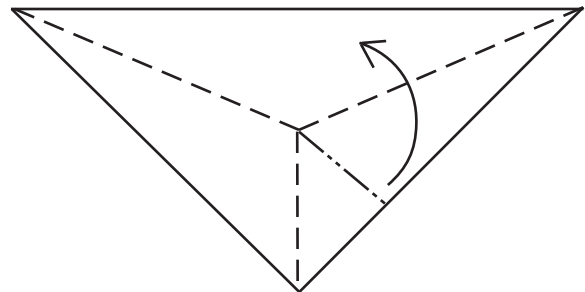

2. Fold the sides up in to a rabbits ear, or make the fish base, which ever you prefer.

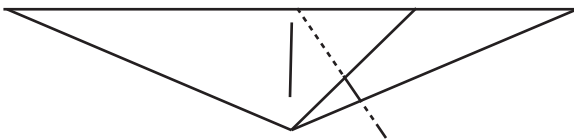

3. Reverse fold the end down from the center
So that it is center in the middle of the model.

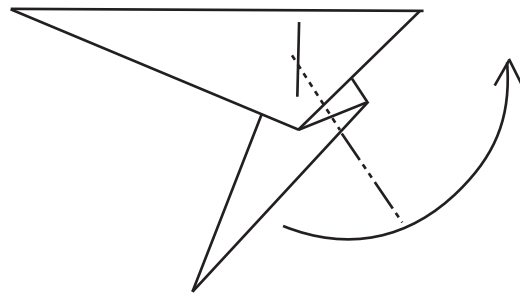

4. Reverse fold the flap part of the way back up.

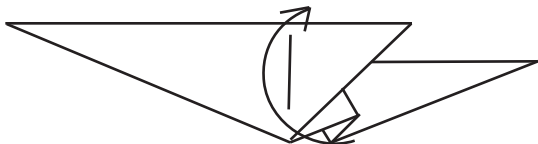

5. The model should look like this
at this point. Now with out
creasing the top layers open
up the bottom of the model.

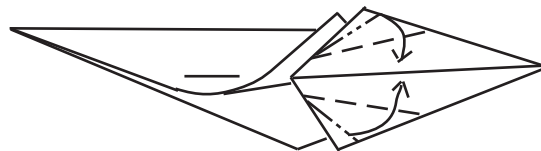

6. Swivel fold the sides into the center of the
model to flare the tail.

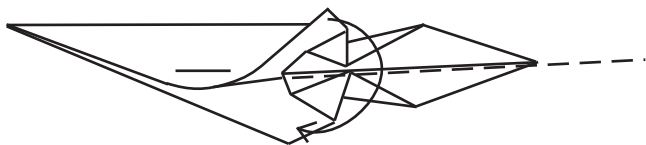

7. It should have at least a vague resemblance
to this, if it does then fold the bottom of the
model back down.

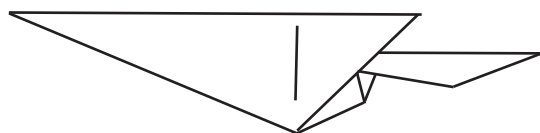

8. If all has gone well it should look like
this, if it does then go on to the next
step.

9. Mountain fold the trailing edge of body back into it's self to do this you probably will need to make a small swivel fold in the tail.

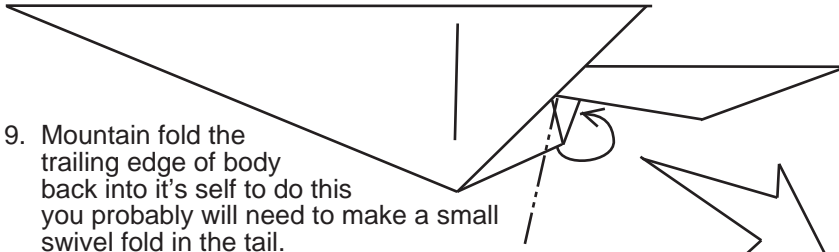

X-ray view of inside of tail if the top layers were removed.

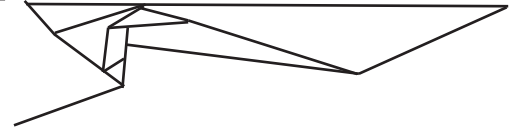

10. The swivel fold inside would look like this.

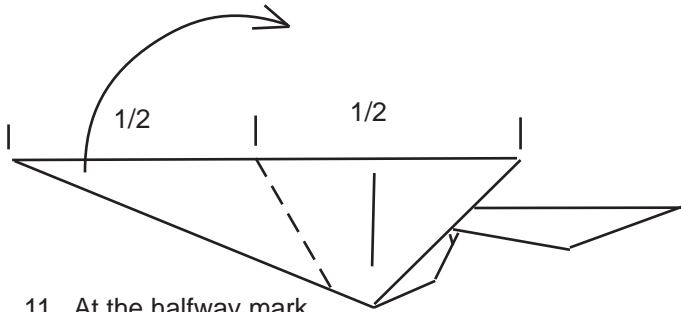

11. At the halfway mark on the top edge reverse fold the front of the model up.

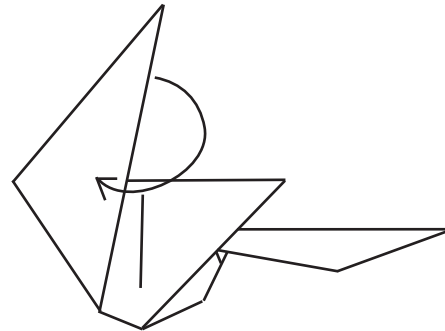

12. Now release the trapped layer of paper on each side and fold it forward. If you were to make this with regular kami (color one side white the other) you would be making a partial color change.

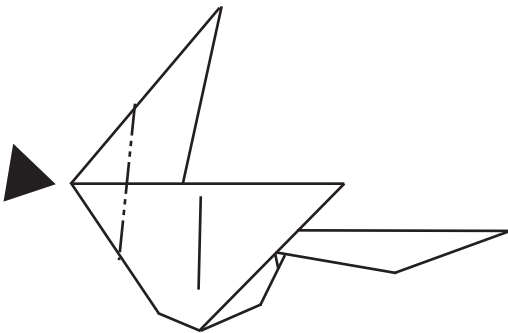

13. Sink the center layer in and then fold the outer layers into the inner sink.

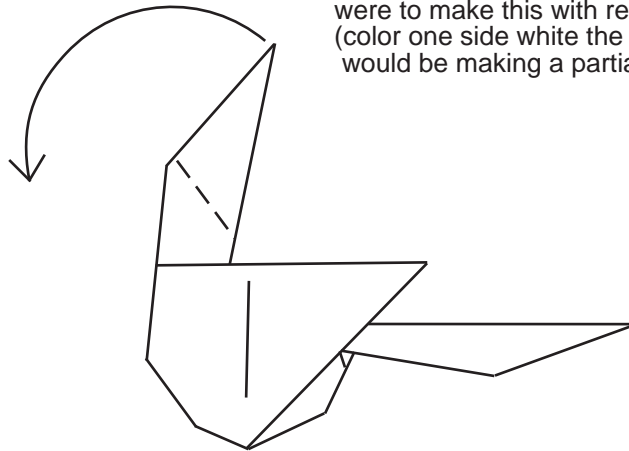

14. Reverse fold the head forward.

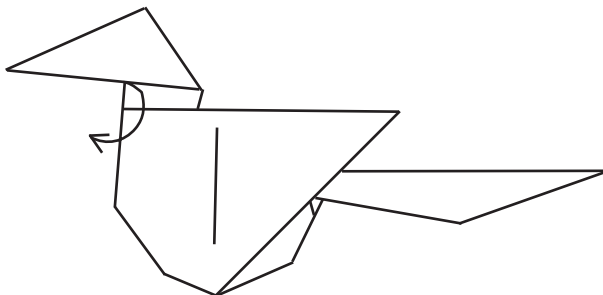

15. Now pull out the trapped layers inside of the head to make it larger.

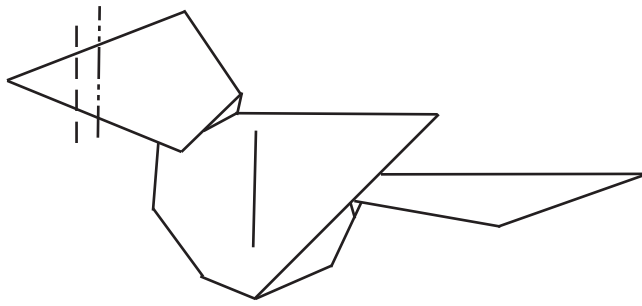

16. Pleat the beak in a bit.

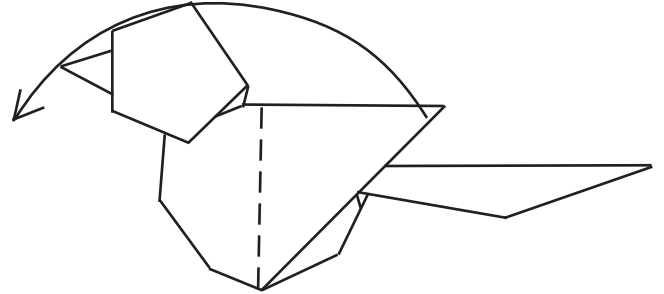

17. Fold the flaps forward, they are about to become wings!

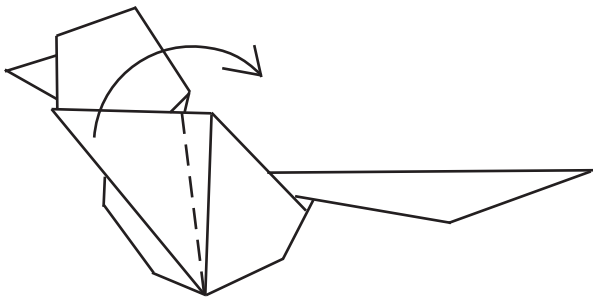

18. Fold the flaps back at a jaunty angle for the wings!

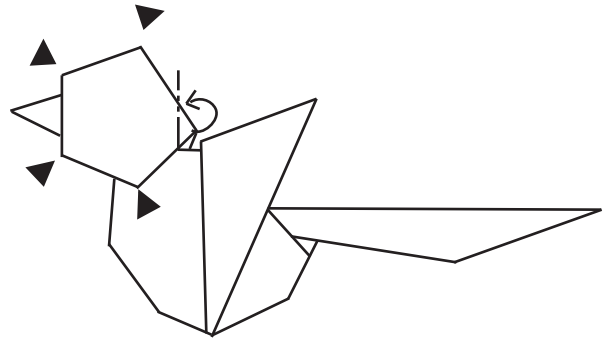

19. These are the finishing touches. Fold the back of the head in to the body, then sink the top of the head and the next spot down in the front of the head, the rest of the head can be managed just fine with mountain folds.

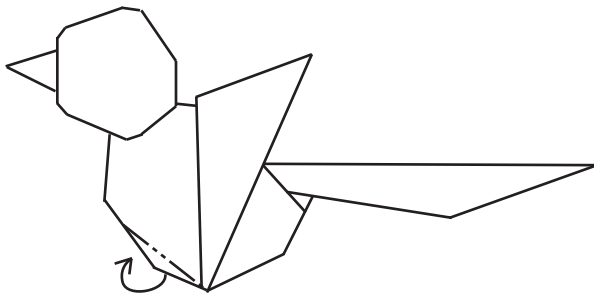

20. Tuck in a little of the breast to improve the lines.

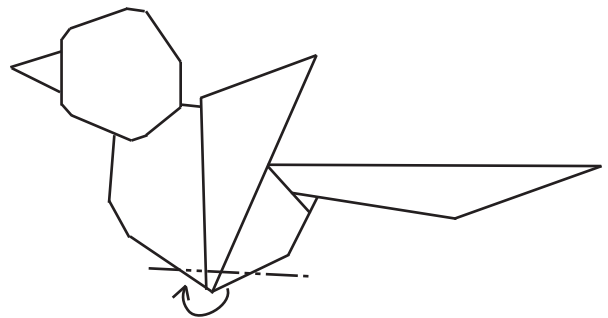

21. Mountain fold a little bit underneath so it will stand properly.

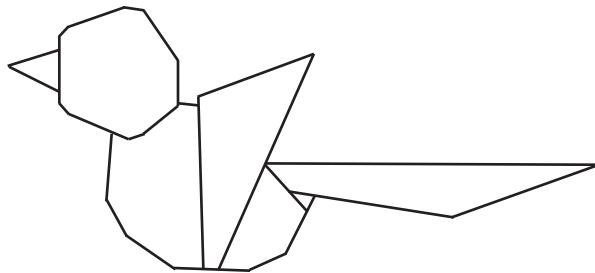

Finally, we are done!